

Technical data sheet for Compacting-unit KWZ-15

Manufacture:

KombiTec GmbH
An der Römerstr. 1

D-87488 Betzigau
Tel: +49 (0) 831 / 960 398 - 0
Fax: +49 (0) 831 / 960 398 - 10

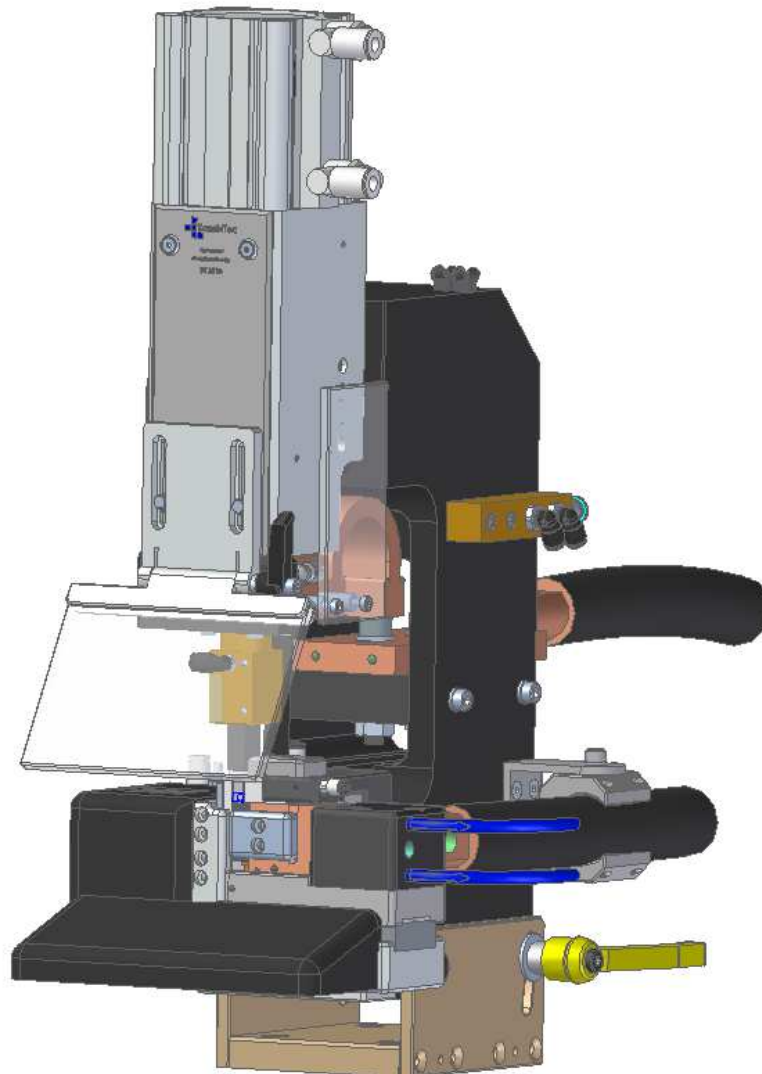

Benefits:

- Compaction of wires **in the passage** possible
- Compact, flexible construction
- Precise positioning-accuracy, stability and robustness due to pre-stressed ball-bearings
- Highest stiffness through shape-connection
- highest reproducibility of given shape- and dimensions
- Simple adjusting of sensors and stroke
- Welding heads individually adjustable
- Simple upgrading opportunities of distance-control and force measuring devices
- Life-time optimized due water-cooled electrodes

Application areas:

- Stranded wires between 0,5 mm² - ca. 12,0 mm²
- Precise compacting of multi-wires
- Strands can be compacted throughout
- Maximum compacting length 15,0 mm

Technical changes:

Technical modification and price changes without notices. All dimensions are in „mm“.
No liability can be accepted for printing errors.

Technical data:

Cylinder-diameter of drive:	Ø 40 mm / Ø 63 mm
Theoretical force (at 5 bar):	ca. 1.500 N (move out, with Cyl.-Ø 63 mm)
Pressed air:	Filtered, 5 µm, oiled or dry
Pneumatic fittings:	G 1/4" / G 1/8"
Pneumatic hose:	Ø 6 mm and Ø 8 mm
Working pressure:	3 – 7 bar
Working temperature:	0 °C – 60 °C
Repeatability:	± 0,01 mm
Max. Weight of the electrode holder:	m = 1 kg
Max. Stroke:	-
Max. Hub:	50 mm
Air consumption per cycle:	0,20 l (at 5 bar and max. stroke)
Total weight:	ca. 12,5 kg (without welding head stator)

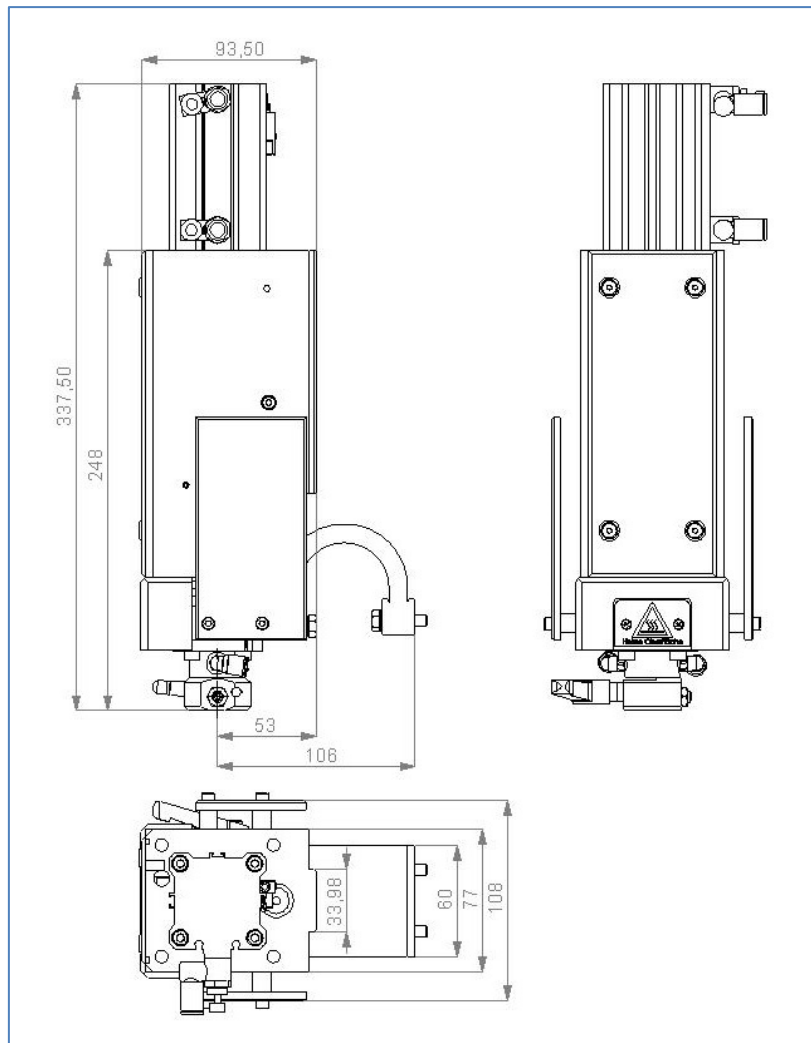

Compacting-unit KWZ-15

Option of configuration:

